

The Original Dome Valve Range



Material Isolation Valves for Pneumatic Conveying Systems
and Bulk Handling Applications

Schenck Process Group – Your Partner Worldwide



Acting locally to support your needs the Schenck Process Group is working where you are.

With a global network of sites and competent partners, the name Schenck Process is synonymous throughout the world with process expertise and well-engineered measuring technology for industrial weighing, feeding, conveying, screening, automation and air filtration technology.

Our key skills include planning processes, feeding bulk materials, controlling flows of material, recording flows of goods, weighing goods and automating transport processes.

Members of the Schenck Process Group are:



To date, more than 40,000 Original Dome Valves have been sold worldwide, for applications across a range of industries including: food, pharmaceuticals, chemicals, plastics, minerals, power, iron and steel.

The Original Dome Valve Range

The most effective bulk material handling valve in the world.



The highly innovative and well proven Original Dome Valve from Schenck Process is reputedly the most effective fast closing, bulk material handling valve in the world. The Original Dome Valve was developed by Clyde Materials Handling* in 1974 for use with pneumatic conveying systems and as a standalone product.

Product advantages

- Full bore unobstructed material flow
- Can cut through moving and some static columns of material
- Designs can be provided for pressures up to 35 bar (507 psi)
- Up to 3,000,000 cycles between major overhauls with most materials/applications
- Fast operating function
- Extremely quick seal replacement
- Long operating life
- Manufactured in accordance with European Pressure Vessel Directive 97/23/EC, BSEN13445, BSEN14460, BSEN1127 and BSEN12516
- Can be provided to ATEX Group II Cat 3D requirements

Comprehensive design features

- Wide range of valve sizes: 50 mm (2") to 750 mm (30")
- 10 bar design pressure as standard
- Can handle material temperatures up to +480 °C (896 °F)
- Forms pressure tight seal when closed
- Inflatable seal leakage detection system to check correct operation every cycle
- Simple, fully proven and reliable design
- Low maintenance
- Suitable for vacuum applications

*Clyde Materials Handling Ltd was purchased by Schenck Process in 2011

Wide Range of Process Applications



Industry applications

The Dome Valve is suited to applications in a wide range of industries from food, pharmaceutical to mineral and plastics to metals. Capable of cutting through flowing material and some static columns, the valve handles abrasive, cohesive, fine and dry products with equal ease.

High reliability with minimal maintenance

The Original Dome Valve has a world-wide reputation for reliability. This results from its simple, cavity-free construction which is designed to minimise the possibility of material build-up within the valve body. The same, simple design philosophy also eases the task of preventative routine maintenance and makes any parts replacement a quick and simple task.

Typical applications include

- Pressure vessel: inlet valve, outlet valve, vent valve
- Precipitator dust collection outlet valve
- Blast furnace dust collection outlet 'dustcatcher' valves
- Conveying pipe: isolation valve
- Diverter pipe: line switching valve
- Outlet to screw feeders
- Outlet to silos
- Isolating valve to reactor vessels
- Lock hopper system valves



Seal Operating Sequence

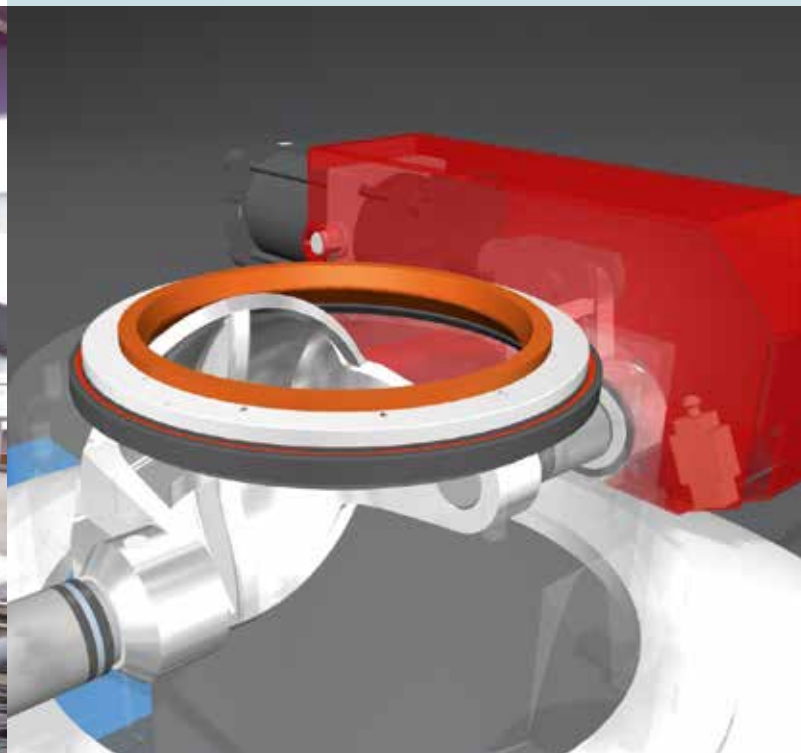

The range of materials that can be handled include

- Detergents
- Minerals
- Ores
- Chemicals
- Fly ash
- Granules
- Powders
- Sand
- Additives
- Electronic scrap
- Dusts
- Pulverised coal/granular coal
- Cement
- Gypsum

Dome closed, seal inflated

The seal automatically inflates only when the dome is fully closed.

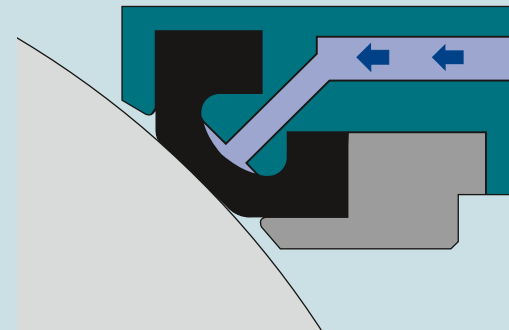

Dome closing, seal deflated

The seal automatically deflates during opening and closing, thereby avoiding contact with the dome and eliminating unnecessary wear.

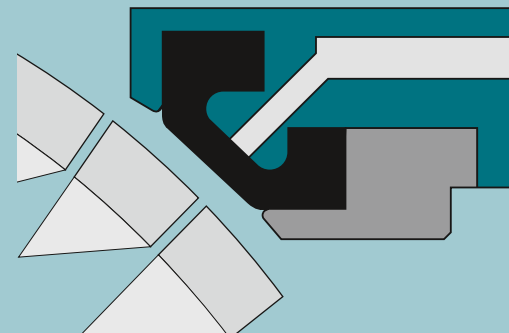

Extensive Range of Dome Valve Product Options



Chrome or ENP
For sticky and abrasive materials



Epoxy resin
For corrosive materials



Tungsten carbide or ENP
For abrasive materials



Reinforced PTFE
For food, sticky or wet materials

Choice of 'dome' finishes to handle a wide range of materials

These coatings can also be extended to the internal surfaces of the valve body and the adaptors.

Materials from fine abrasive powders to a very cohesive substances may require different 'dome' finishes in terms of raw material or surface coatings. The dome is usually produced from SG iron or stainless steel, but other materials and designs can be considered on application.



Dump valves and terminal boxes

Dump valves are used where a number of hoppers positioned in series require selective feeding. They have two operating conditions, 'straight through' and 'dump'. In the straight through condition, a self-inflating easily replaceable seal closes off the respective hopper inlet, allowing the material to be conveyed 'straight through' to the next available reception point.



Switch valves

These types of valves are used for diverting flow in any pneumatic conveying lines or hopper discharge applications and are particularly suitable for abrasive materials. They can also be supplied if operating pressures and temperatures are high. Switch valves are fitted with two Original Dome Valves for line isolation and can be provided with multiple discharges or inlets.



Constant discharge lock hoppers

Lock hoppers provide constant discharge from collection vessels. They are mainly used if the product is abrasive or when operating temperatures and pressures are high. Since the assembly is normally pressure balanced with the up and downstream equipment, valve wear is negligible.



Water cooled ball valve

Water cooled ball valve and clamp valve suitable for products at temperatures between 480°C and 750°C. Units fitted with replaceable inlet liner. Commonly used for the handling of hot DRI pellets.

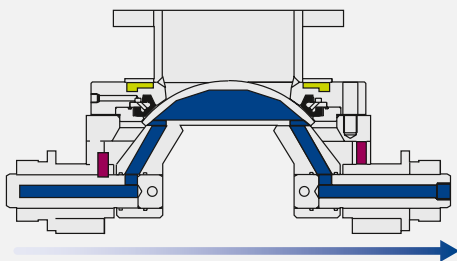

Water flow

- PH1: water cooled top plate only
- PH2: as PH1 but including a water cooled dome
- PH3: as PH2 but including a water cooled body

Water cooled Original Dome Valve options

Water cooling is recommended for applications involving temperatures in excess of 200°C. Water cooled valves are available in three options in selective sizes throughout the range.

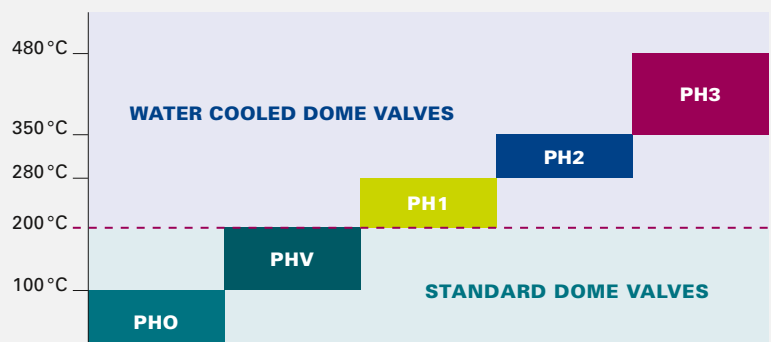

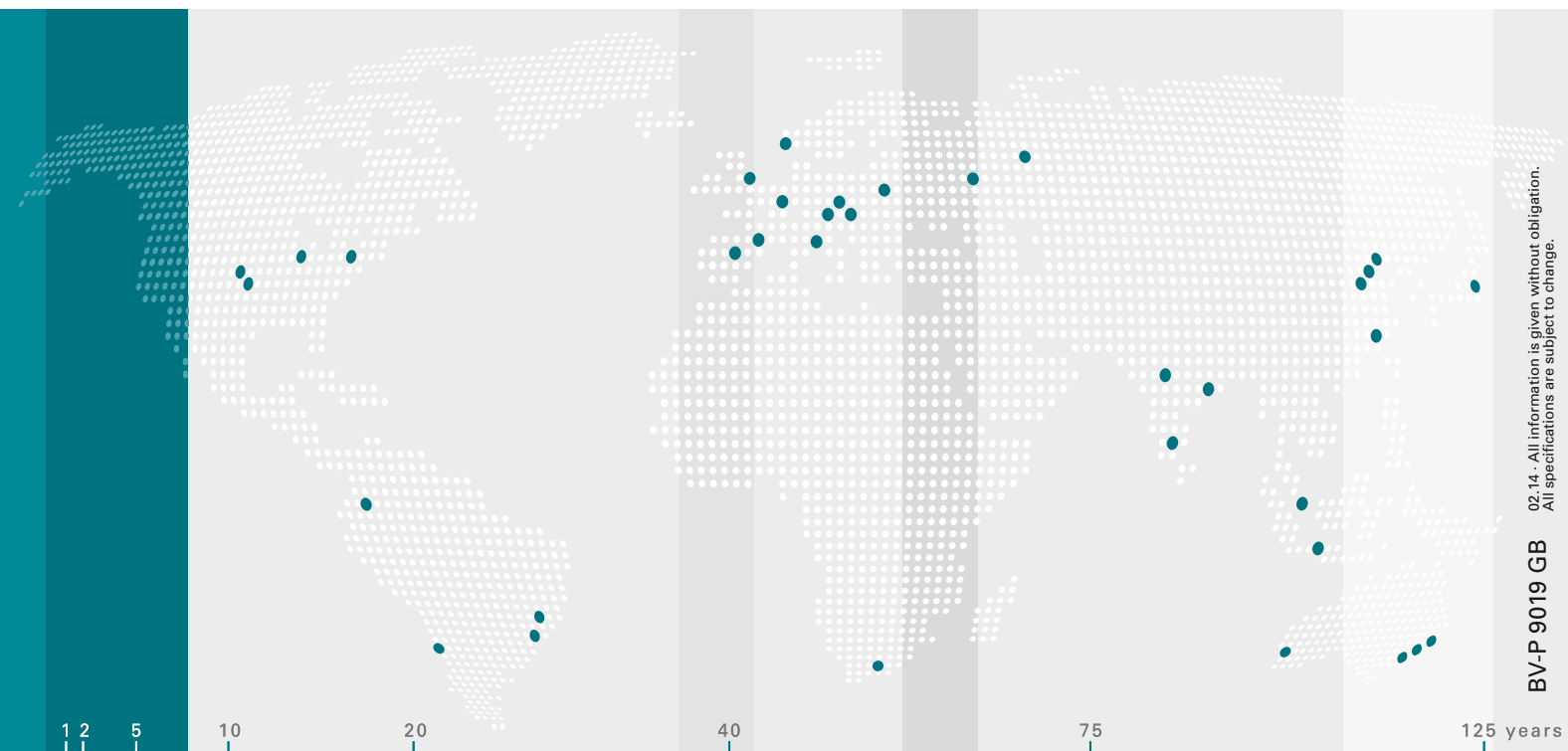

02.14 - All information is given without obligation.
All specifications are subject to change.

BV-P 9019 GB

The Schenck Process Group is a global market leader in industrial weighing and feeding technology /// screening and separation systems for bulk materials /// dust collection and air filtration technology /// pneumatic and mechanical conveying solutions /// automation and diagnostic technology

Schenck Process UK Ltd
Carolina Court, Lakeside
Doncaster, DN4 5RA, United Kingdom
T +44 (0)1302 321 313
F +44 (0)1302 554 400
enquiries@schenckprocess.co.uk
www.schenckprocess.co.uk

Schenck Process GmbH
Pallaswiesenstr. 100
64293 Darmstadt, Germany
T +49 61 51-15 31 0
sales@schenckprocess.com
www.schenckprocess.com

we make processes work